



# OneStop

---

## REVALUE STATION



### Cash, Credit, or Code... It's your choice.

The Heartland Micropayments OneStop Revalue Station accepts credit cards, cash, and Code Based loads to add value to electronic cash cards. Your consumers have the choice to use whatever payment method they prefer. The unit also features an easy-to-read display, optional card dispenser, and an integrated printer. Setup is fast and easy, requiring only a standard power connection and a single telephone line, or LAN Connection.

The OneStop helps keep operating costs to a minimum. Save time on reconciliation with full reporting from both Heartland's Online Merchant Center ([www.heartlandpaymentsystems.com/OMCDemo/](http://www.heartlandpaymentsystems.com/OMCDemo/)) and the internal report generation capabilities of the unit.

The OneStop is component-based and is offered in three mounting options – front opening wall, back opening wall, and pedestal.

Credit card transactions are processed through Heartland Payment Systems' state-of-the-art processing platform.



**The OneStop Revalue Station provides the following features and functionality:**

▪ **Benefits & Advantages**

- ✓ Full reporting capabilities
- ✓ Quiet and fast thermal printer with easy-loading mechanism
- ✓ Mechanical, non-resettable counters

▪ **Chip Card Revalue Sources**

- ✓ Cash
- ✓ Credit cards (provides SSL security)
- ✓ Code Based Revalue (adds & refunds)

▪ **Card Dispensing Options**

- ✓ Cards may be purchased by Cash, Codes purchased on a provider's RevalueMyCard website, or by credit/debit card.

▪ **Remote Capabilities**

- ✓ Provides the ability to download and upgrade firmware remotely.
- ✓ Provides the ability to download parameter changes remotely.
- ✓ Provides the ability to perform set-up remotely.
- ✓ Provides remote management reporting including cash count reports by bill type/dollar breakdown. Remote management also includes error reporting, exception reporting, and real-time polling for data collection.

▪ **Connectivity Options**

- ✓ TCP/IP
- ✓ Wi-Fi
- ✓ Dial up

▪ **Component Options**

- ✓ Card dispenser
- ✓ Receipt printer
- ✓ Remote data collection
- ✓ Code Based Revalue
- ✓ Pedestal mounting

Technical Specifications - OneStop	
Physical Dimensions	22.25"H X 14"W X 12"D
Weight	85 lbs (with mounting rails)
Physical Security	Robust construction of 11ga Cold-Rolled Steel, High Security Lock
Exterior Finish	Corrosion resistant Powder Coat, Low Texture
Electrical Requirements	120 VAC, < 2 Amp max load
Electronic Security	Non-resettable counter, PCI Compliant, Automatic Shutdown, Remote Auditing, 5-yr Battery Backup
Remote Management	Financial Auditing, Application Upgrades, Parameters Changes, Set-Up
Communications	SSL Security - TCP/IP (CAT5), Wireless (802.11G), Dial-Modem
Add Value Methods	Cash, Credit, Code Based
Card Dispenser Capacity	120 Cards (30 mil)
Bill Validator	\$1, \$5, \$10, \$20 - Standard (\$50, \$100 - Optional)
Bill Stacker Capacity	300 bills - Standard, (up to 700 bills - Optional)
Receipt Printer	Thermal - 2.25" paper size (approx. 140 receipts per roll)
Operating Temperature	41 F to 104 F (+5 C to +40 C)
Relative Operating Humidity	20% - 80%, non-condensing
Access Options	Rear Access, Front Access
Mounting Options	Wall Mounted, Recessed, Pedestal

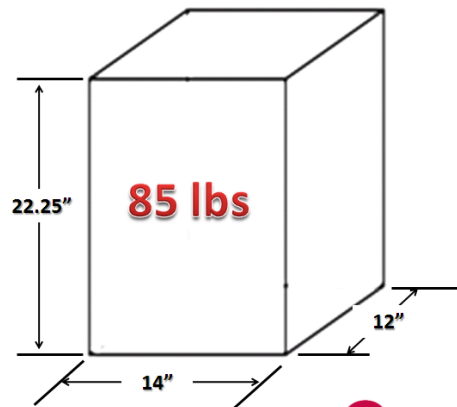

**OneStop**  
REVALUE STATION